



SERVICE MANUAL

Room Air Conditioner

Multi Split Wall-Mounted Type Indoor



FSAI-Pro-91AE2
FSAI-Pro-121AE2
FSAIF-Pro-181AE2

NOTE:

Before servicing the unit, please read this at first.

Always contact with your service center if meet problem.

FI_SM_Multi indoor_FSAI-Pro-91-121-181-241AE2_141105

CONTENTS

1. Precaution.....	3
1.1 Safety Precaution.....	3
1.2 Warning.....	3
2. Function.....	7
3. Dimension.....	8
4. Wiring Diagram.....	9
5. Operation Characteristics.....	10
6. Electronic function.....	11
6.1 Abbreviation.....	11
6.2 Display function.....	11
6.3 Main Protection.....	12
6.4 Operation Modes and Functions.....	13

1. Precaution

1.1 Safety Precaution

■ To prevent injury to the user or other people and property damage, the following instructions must be followed.

- Incorrect operation due to ignoring instruction will cause harm or damage.
- Before service the unit, be sure to read this service manual at first.

1.2 Warning

➤ Installation

■ Do not use a defective or underrated circuit breaker. Use this appliance on a dedicated circuit.

There is risk of fire or electric shock.

■ For electrical work, contact the dealer, seller, a qualified electrician, or an authorized service center.

Do not disassemble or repair the product, there is risk of fire or electric shock.

■ Always ground the product.

There is risk of fire or electric shock.

■ Install the panel and the cover of control box securely.

There is risk of fire of electric shock.

■ Always install a dedicated circuit and breaker.

Improper wiring or installation may cause fire or electric shock.

■ Use the correctly rated breaker or fuse.

There is risk of fire or electric shock.

■ Do not modify or extend the power cable.

There is risk of fire or electric shock.

■ Do not install, remove, or reinstall the unit by yourself (customer).

There is risk of fire, electric shock, explosion, or injury.

■ Be caution when unpacking and installing the product.

Sharp edges could cause injury, be especially careful of the case edges and the fins on the

condenser and evaporator.

- **For installation, always contact the dealer or an authorized service center.**
- **Do not install the product on a defective installation stand.**
- **Be sure the installation area does not deteriorate with age.**

If the base collapses, the air conditioner could fall with it, causing property damage, product failure, and personal injury.

- **Do not let the air conditioner run for a long time when the humidity is very high and a door or a window is left open.**

- **Take care to ensure that power cable could not be pulled out or damaged during operation.**

There is risk of fire or electric shock.

- **Do not place anything on the power cable.**

There is risk of fire or electric shock.

- **Do not plug or unplug the power supply plug during operation.**

There is risk of fire or electric shock.

- **Do not touch (operation) the product with wet hands.**

- **Do not place a heater or other appliance near the power cable.**

There is risk of fire and electric shock.

- **Do not allow water to run into electrical parts.**

It may cause fire, failure of the product, or electric shock.

- **Do not store or use flammable gas or combustible near the product.**

There is risk of fire or failure of product.

- **Do not use the product in a tightly closed space for a long time.**

Oxygen deficiency could occur.

- **When flammable gas leaks, turn off the gas and open a window for ventilation before turn the product on.**

- **If strange sounds or smoke comes from product, turn the breaker off or disconnect the power supply cable.**

There is risk of electric shock or fire.

- **Stop operation and close the window in storm or hurricane. If possible, remove the product from the window before the hurricane arrives.**

There is risk of property damage, failure of product, or electric shock.

- **Do not open the inlet grill of the product during operation. (Do not touch the electrostatic filter, if the unit is so equipped.)**

There is risk of physical injury, electric shock, or product failure.

- **When the product is soaked, contact an authorized service center.**

There is risk of fire or electric shock.

- **Be caution that water could not enter the product.**

There is risk of fire, electric shock, or product damage.

- **Ventilate the product from time to time when operating it together with a stove etc.**

There is risk of fire or electric shock.

- **Turn the main power off when cleaning or maintaining the product.**

There is risk of electric shock.

- **When the product is not be used for a long time, disconnect the power supply plug or turn off the breaker.**

There is risk of product damage or failure, or unintended operation.

- **Take care to ensure that nobody could step on or fall onto the outdoor unit.**

This could result in personal injury and product damage.

➤ CAUTION

- **Always check for gas (refrigerant) leakage after installation or repair of product.**

Low refrigerant levels may cause failure of product.

- **Install the drain hose to ensure that water is drained away properly.**

A bad connection may cause water leakage.

- **Keep level even when installing the product.**

It can avoid vibration of water leakage.

- **Do not install the product where the noise or hot air from the outdoor unit could damage the neighborhoods.**

It may cause a problem for your neighbors.

- **Use two or more people to lift and transport the product.**

- **Do not install the product where it will be exposed to sea wind (salt spray) directly.**

It may cause corrosion on the product. Corrosion, particularly on the condenser and evaporator fins,

could cause product malfunction or inefficient operation.

➤ **Operational**

- **Do not expose the skin directly to cool air for long time. (Do not sit in the draft).**
- **Do not use the product for special purposes, such as preserving foods, works of art etc.**

It is a consumer air conditioner, not a precision refrigerant system.

There is risk of damage or loss of property.

- **Do not block the inlet or outlet of air flow.**
- **Use a soft cloth to clean. Do not use harsh detergents, solvents, etc.**

There is risk of fire, electric shock, or damage to the plastic parts of the product.

■ **Do not touch the metal parts of the product when removing the air filter. They are very sharp.**

- **Do not step on or put anything on the product. (outdoor units)**
- **Always insert the filter securely. Clean the filter every two weeks or more often if necessary.**

A dirty filter reduces the efficiency of the air conditioner and could cause product malfunction or damage.

■ **Do not insert hands or other objects through air inlet or outlet while the product is operated.**

- **Do not drink the water drained from the product.**
- **Use a firm stool or ladder when cleaning or maintaining the product.**

Be careful and avoid personal injury.

■ **Replace the all batteries in the remote control with new ones of the same type. Do not mix old and new batteries or different types of batteries.**

There is risk of fire or explosion.

- **Do not recharge or disassemble the batteries. Do not dispose of batteries in a fire.**

They may burn or explode.

■ **If the liquid from the batteries gets onto your skin or clothes, wash it well with clean water. Do not use the remote if the batteries have leaked.**

2. Function

Model Names of Indoor/Outdoor Units

	Capacity	Model
DC Inverter Multi Series	7K	FSAMI-Pro-71AE2
	9K	FSAI-Pro-91AE2
	12K	FSAI-Pro-121AE2
	18K	FSAIF-Pro-181AE2

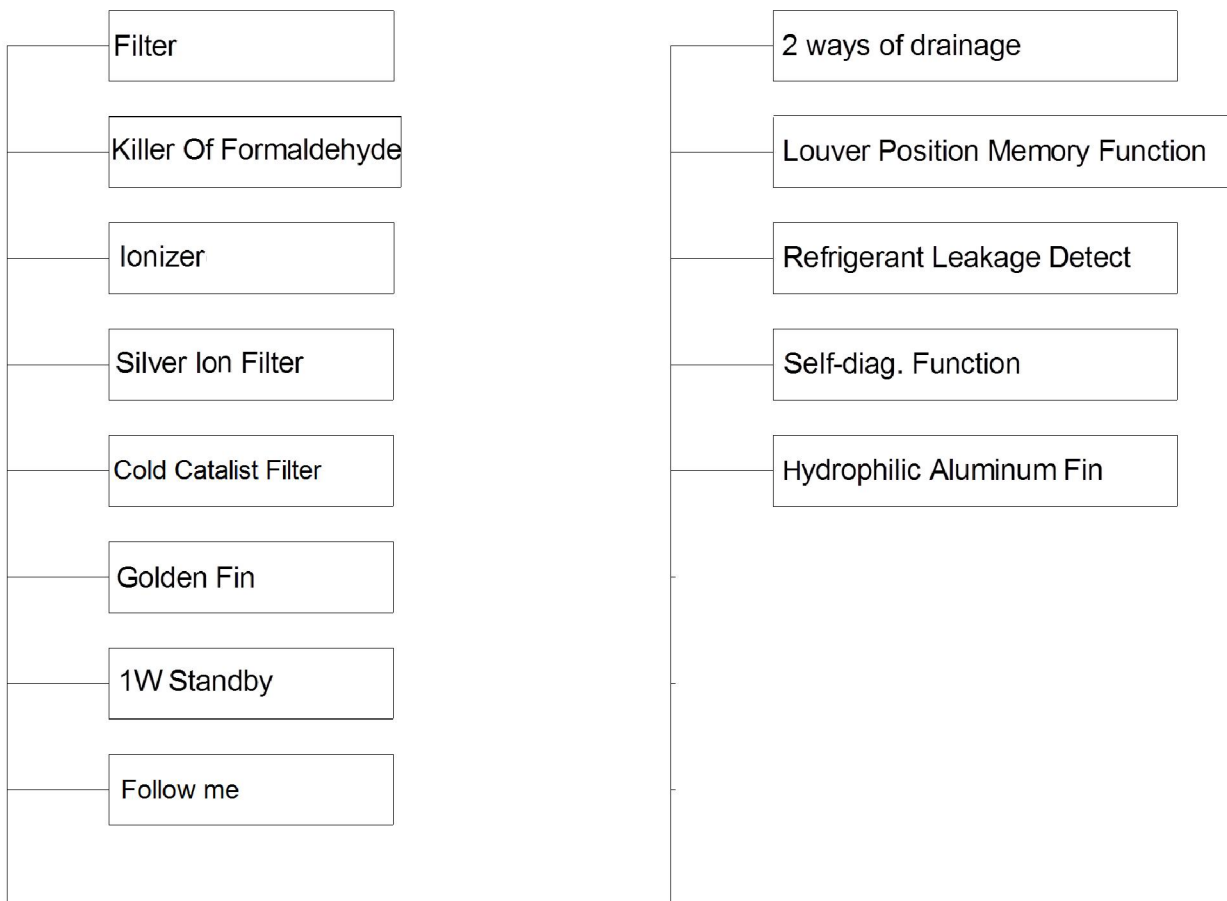

3. Dimension

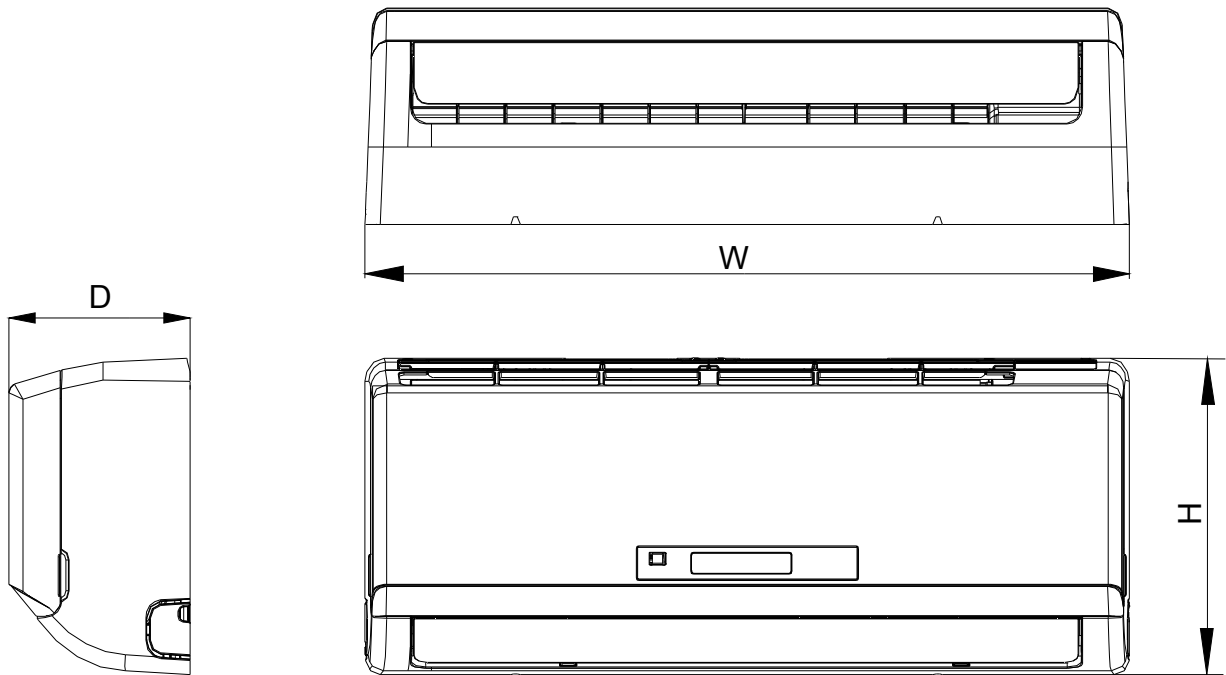

Model	W	D	H
FSAMI-Pro-71AE2	800	188	275
FSAI-Pro-91AE2	800	188	275
FSAI-Pro-121AE2	800	188	275
FSAIF-Pro-181AE2	940	205	275

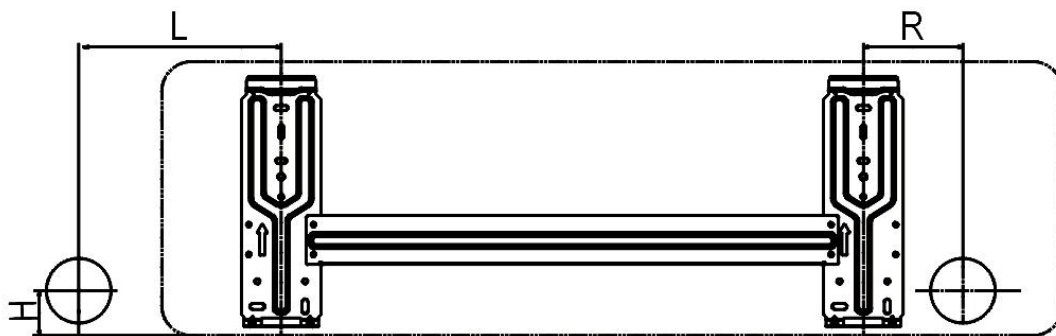

Model	L(mm)	R(mm)	H(mm)	Dimension of installation hole(mm)
FSAMI-Pro-71AE2	100	95	45	∅ 65
FSAI-Pro-91AE2				
FSAI-Pro-121AE2				
FSAIF-Pro-181AE2	110	100	45	

4. Wiring Diagram

FSAI-Pro-91AE2, FSAI-Pro-121AE2,

NOTE: If used as MONO unit, for the standby control needs, the cross section area of cable connected to W,1(L), 2(N) must be sufficient for the maximum system current. The maximum system current is equal to the sum of indoor unit and outdoor unit rated current. If used as MULTI unit, W on the terminal block does not need to be connected.

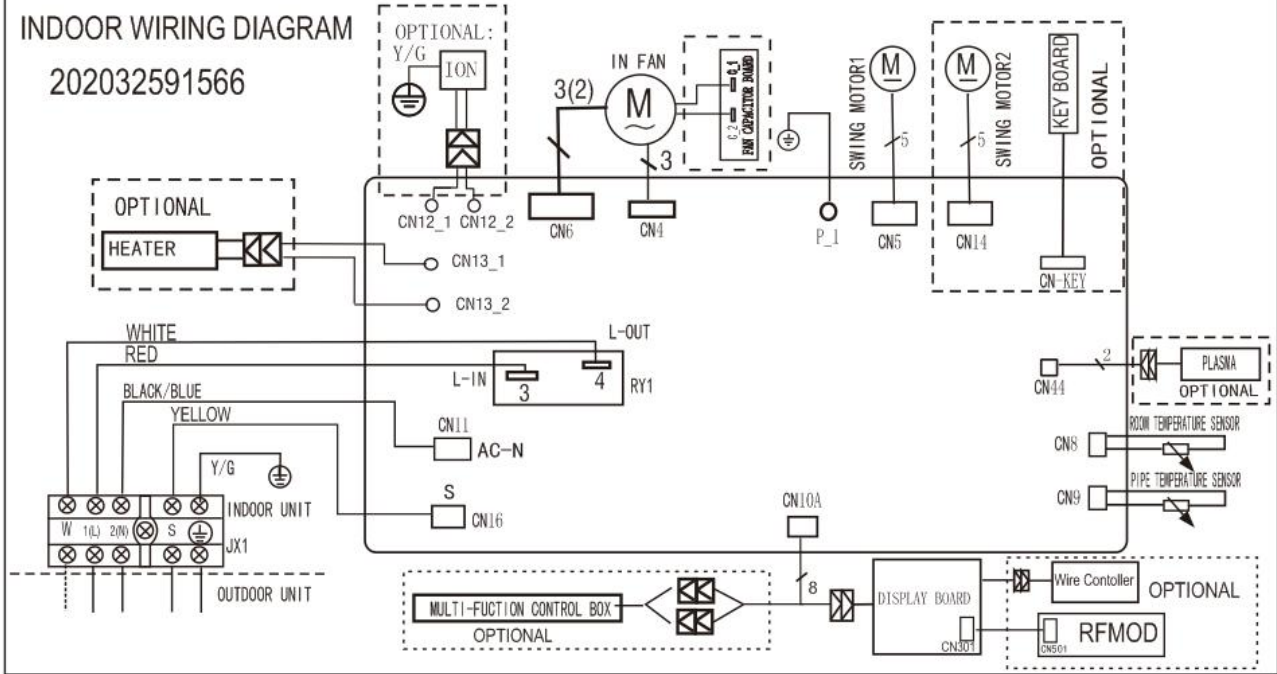

FSAIF-Pro-181AE2

NOTE: If used as MONO unit, for the standby control needs, the cross section area of cable connected to W, 1(L) must be sufficient for the maximum system current. The maximum system current is equal to the sum of indoor unit and outdoor unit rated current. If used as MULTI unit, W on the terminal block does not need to be connected.

202032891454

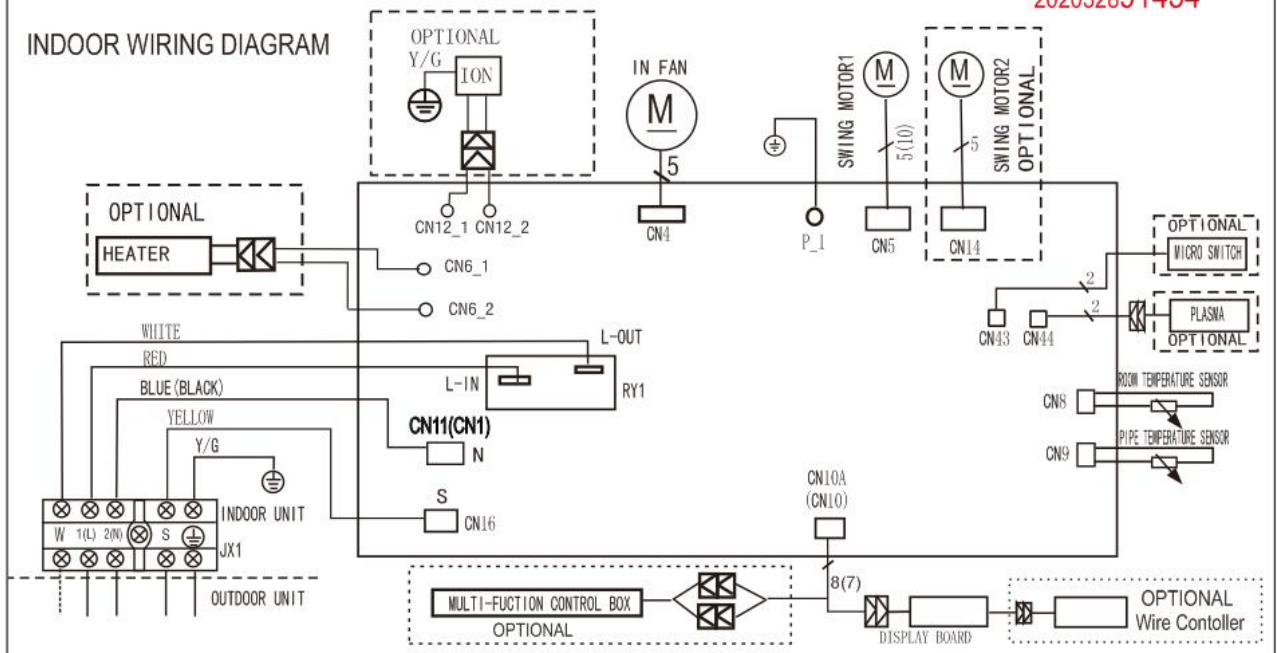

5. Operation Characteristics

Temperature Mode	Cooling operation	Heating operation	Drying operation
Room temperature	+17°C ~ +32°C	0°C ~ +30°C	+10°C ~ +32°C
Outdoor temperature	0°C ~ 50°C	-15°C ~ 24°C	0°C ~ 50°C
	-15°C ~ 50°C (For the models with low temperature cooling system)		

CAUTION:

1. If the air conditioner is used beyond the above conditions, certain safety protection features may come into operation and cause the unit to operate abnormally.

2. The room relative humidity should be less than 80%. If the air conditioner operates beyond this figure, the surface of the air conditioner may attract condensation. Please set the vertical air flow louver to its maximum angle (vertically to the floor), and set HIGH fan mode.

3. The optimum performance will be achieved during this operating temperature zone.

6. Electronic function

6.1 Abbreviation

T1: Indoor room temperature

T2: Coil temperature of evaporator

T3: Coil temperature of condenser

T4: Outdoor ambient temperature

T5: Compressor discharge temperature

6.2 Display function

8.2.1 Icon explanation on indoor display board.

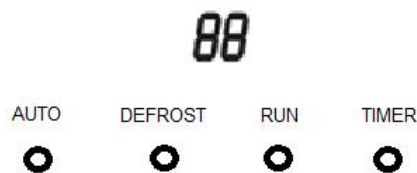

AUTO	Auto indicator: This indicator illuminates when the air conditioner is in AUTO operation.
DEFROST	PRE.-DEF. Indicator: This indicator illuminates when the air conditioner starts defrosting automatically or when the warm air control feature is activated in heating mode.
RUN	OPERATION indicator: This indicator illuminates when the air conditioner is running.
TIMER	Timer indicator: This indicator illuminates when TIMER is set ON/OFF
	Temperature indicator: Displays the temperature settings when the air conditioner is operational, displays the room temperature in FAN mode. Displays the malfunction code.

6.3 Main Protection

6.3.1 Time delay at restart for compressor

1 minute delay for the 1st time start-up and 3 minutes delay for others.

6.3.2 Fan speed is out of control

When Indoor Fan Speed keeps too low (300RPM) for certain time, the unit will stop and the LED will display the failure

6.3.3 Inverter module protection

The Inverter module has a protection function about current, voltage and temperature. If these protections happen, the corresponding code will display on indoor unit and the unit will stop working.

6.3.4 Indoor fan delayed open function

When the unit starts up, the louver will be active immediately and the indoor fan will open 10s later.

If the unit runs in heating mode, the indoor fan will be also controlled by anti-cold wind function.

6.3.5 Sensor protection at open circuit and breaking disconnection.

6.3.6 Zero crossing detection error protection (except FSAIF-Pro-181AE2)

If AC detects time interval is not correct for continuous 240s, the unit will stop and the LED will display the failure. The correct zero crossing signal time interval should be between 6-13ms.

6.4 Operation Modes and Functions

6.4.1 Fan mode

- (1) Outdoor fan and compressor stop.
- (2) Temperature setting function is disabled, and no setting temperature is displayed.
- (3) Indoor fan can be set to high/med/low/auto.
- (4) The louver operates same as in cooling mode.
- (5) Auto fan:

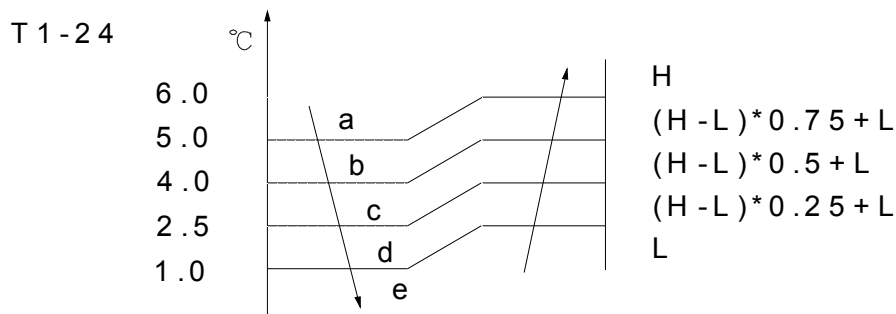

6.4.2 Cooling Mode

6.4.2.1 Compressor running rules

The compressor will run at corresponding frequency according to the gross amendatory capacity demand.

Frequency	COOL_F0	COOL_F1	COOL_F2	COOL_F15	COOL_F16
Amendatory capacity demand.	0	1	2	15	16

Meanwhile the maximum running frequency will be adjusted according to the outdoor ambient temp.

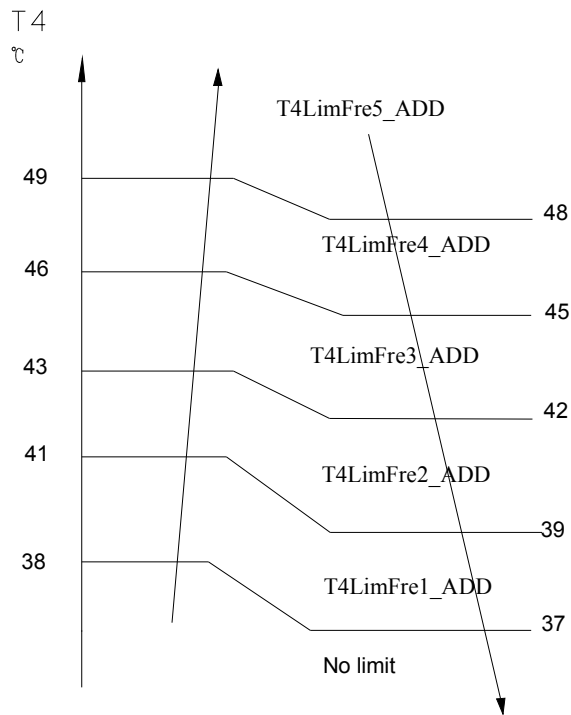

6.4.2.2 Outdoor fan running rules

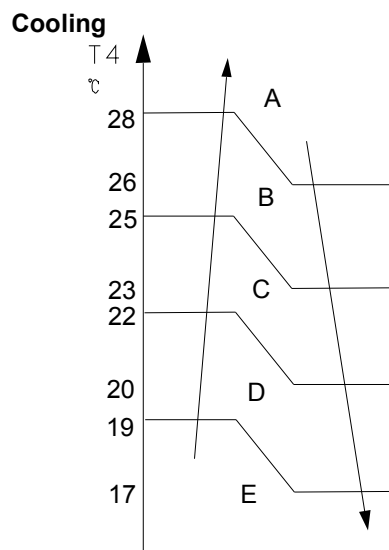

While A,B,C...means different fan speed of outdoor unit.

6.4.2.3 Indoor fan running rules

In cooling mode, indoor fan runs all the time and the speed can be selected as high, medium, low and auto. When the compressor is running, the indoor fan is controlled as below:

Setting Fan speed	T1-Ts		Actual fan speed
H	4.5	A	$H+(H+=H+G)$
	3.0	B	$H (=H)$
	1.5	C	$H- (H=H-G)$
M	4.5	D	$M+(M+=M+Z)$
	3.0	E	$M(M=M)$
	1.5	F	$M-(M-=M-Z)$
L	4.5	G	$L+(L+=L+D)$
	3.0	H	$L(L=L)$
	1.5	I	$L-(L-=L-D)$

The auto fan acts as below rules:

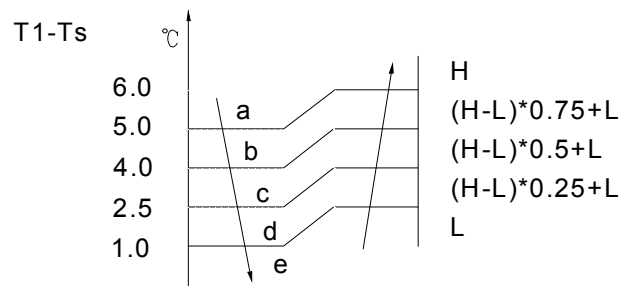

6.4.2.4 Evaporator low temperature T2 protection

When $T2 < 4^{\circ}\text{C}$, the indoor has no capacity demand and resume till $T2 > 8^{\circ}\text{C}$.

6.4.3 Heating Mode

6.4.3.1 Compressor running rules

The compressor will run at corresponding frequency according to the gross amendatory capacity demand.

Frequency	0	HEAT_F1	HEAT_F2	HEAT_F15	HEAT_F16
Amendatory capacity demand.	0	1	2	15	16

6.4.3.2 Outdoor fan running rules

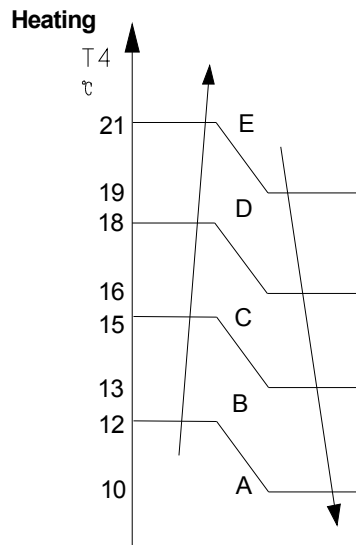

6.4.3.3 Indoor fan running rules

In heating mode, indoor fan can be selected as high, medium, low and auto. The anti-cold- wind function is preferential. The running rules of anti-cold-wind function depend on both T1 and T2 that is more comfortable control.

When the compressor is running, the indoor fan is controlled as below:

Setting fan speed	T1-Ts	Actual fan speed
H	-1.5	H+ (H=H+G)
	-3.0	H (=H)
	-4.5	H+(H+=H+G)
M	-1.5	M-(M-=M-Z)
	-3.0	M(M=M)
	-4.5	M+(M+=M+Z)
L	-1.5	L-(L-=L-D)
	-3.0	L(L=L)
	-4.5	L+(L+=L+D)

Auto fan action in heating mode:

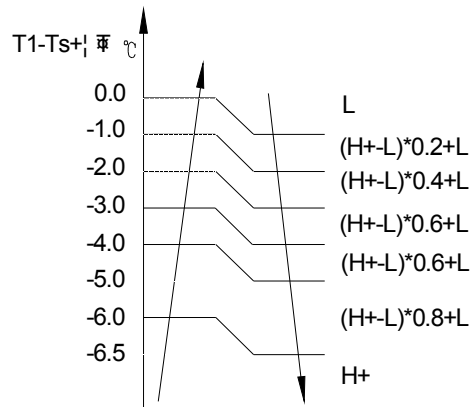

6.4.3.4 Defrosting mode

Condition of defrosting:

If any one of the following items is satisfied, AC will enter the defrosting mode.

After the compressor starts up and keeps running, mark the minimum value of T3 from the 10th minutes to 15th minutes as T30.

1) If the compressor cumulative running time is up to 29 minutes and $T3 < TCDI1$, $T3 + T30SUBT3ONE \leq T30$.

2) If the compressor cumulative running time is up to 35 minutes and $T3 < TCDI2$, $T3 + T30SUBT3TWO \leq T30$.

3) If the compressor cumulative running time is up to 29 minutes and $T3 < TCDI3$ for 3 minutes.

4) If the compressor cumulative running time is up to 120 minutes and $T3 < -15^\circ\text{C}$.

Condition of ending defrosting:

If any one of the following items is satisfied, the defrosting will finish and the machine will turn to normal heating mode.

---T3 rises to be higher than $TCDE1^\circ\text{C}$.

---T3 keeps to be higher than $TCDE2^\circ\text{C}$ for 80 seconds.

---The machine has run for 10 minutes in defrosting mode.

Defrosting action:

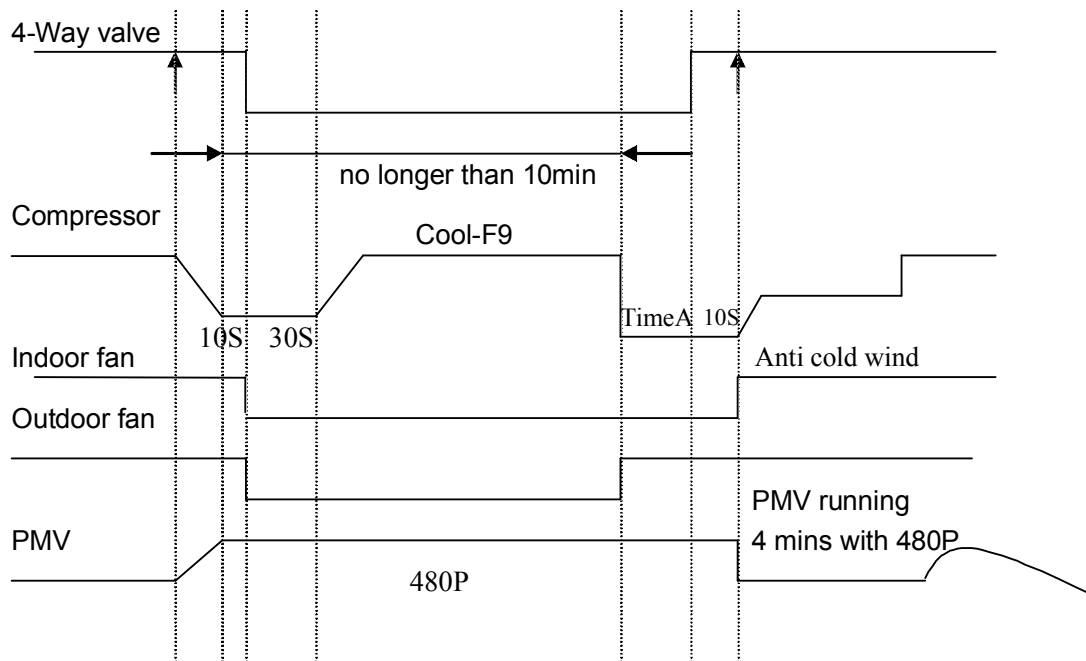

6.4.3.5 High evaporator coil temp. T2 protection:

If $T_2 > 63^\circ\text{C}$, the indoor unit has no capacity demand and resume till 48°C .

6.4.4 Auto-mode

This mode can be chosen with remote controller and the setting temperature can be changed between $17\sim 30^\circ\text{C}$.

In auto mode, the machine will choose cooling, heating or fan-only mode according to ΔT ($\Delta T = T_1 - T_s$).

$\Delta T = T_1 - T_s$	Running mode
$\Delta T > 1^\circ\text{C}$	Cooling
$-1 < \Delta T \leq 1^\circ\text{C}$	Fan-only
$\Delta T \leq -1^\circ\text{C}$	Heating

Indoor fan will run at auto fan of the relevant mode.

The louver operates same as in relevant mode.

If the machine switches mode between heating and cooling, the compressor will keep stopping for 15 minutes and then choose mode according to $T_1 - T_s$.

If the setting temperature is modified, the machine will choose running function again.

6.4.5 Drying mode

6.4.5.1 Indoor fan speed is fixed at breeze and can't be changed. The louver angle is the same as in cooling mode.

6.4.5.2 Low indoor room temperature protection

In drying mode, if room temperature is lower than 10°C, the compressor will stop and not resume until room temperature exceeds 12°C.

6.4.5.3 Evaporator anti-freezing protection, condenser high temperature protection are active and the same as that in cooling mode.

6.4.5.5 The outdoor fan operates the same as in cooling mode.

6.4.6 Forced operation function

6.4.6.1 Enter forced operation function:

Press the touch button continually, the AC will run as below sequence:

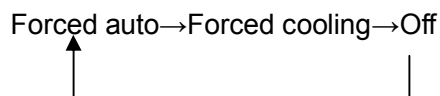

When the machine is off, pressing the touch button will carry the machine to forced auto mode, after this, if pressing the button once again, the machine will turn into forced cooling mode.

In forced cooling mode, pressing touch button will turn off the machine.

6.4.6.2 In forced operation mode, all general protections and remote control are available.

6.4.6.3 Operation rules:

Forced cooling mode:

The compressor runs at F2 frequency and indoor fan runs as breeze. After running for 30 minutes. the machine will turn to auto mode as 24°C setting temperature.

Forced auto mode:

The action of forced auto mode is the same as normal auto mode with 24°C setting temperature.

6.4.6.4 When there's indoor unit running in forced cooling, it is the master forced cooling unit. Other indoor units will run at forced cooling mode too and they will be the slave forced cooling units. The slave forced cooling units cannot quit forced cooling mode until the master forced cooling unit quit, and turn to cooling mode at low speed with 24°C setting temperature.

6.4.6.5 The slave forced cooling units will not be controlled by other signals.

6.4.7 Timer function

6.4.7.1 Timing range is 24 hours.

6.4.7.2 Timer on. The machine will turn on automatically when reaching the setting time.

6.4.7.3 Timer off. The machine will turn off automatically when reaching the setting time.

6.4.7.4 Timer on/off. The machine will turn on automatically when reaching the setting “on” time, and then turn off automatically when reaching the setting “off” time.

6.4.7.5 Timer off/on. The machine will turn off automatically when reaching the setting “off” time, and then turn on automatically when reaching the setting “on” time.

6.4.7.6 The timer function will not change the AC current operation mode. Suppose AC is off now, it will not start up firstly after setting the “timer off” function. And when reaching the setting time, the timer LED will be off and the AC running mode has not been changed.

6.4.7.7 The setting time is relative time.

6.4.8 Sleep function mode

6.4.8.1 Operation time in sleep mode is 7 hours. After 7 hours the AC quits this mode and turns off.

6.4.8.2. Operation process in sleep mode is as follow:

When cooling, the setting temperature rises 1°C (be lower than 30°C) every one hour, 2 hours later the setting temperature stops rising and indoor fan is fixed as low speed.

When heating, the setting temperature decreases 1°C (be higher than 17°C) every one hour, 2 hours later the setting temperature stops rising and indoor fan is fixed as low speed. (Anti-cold wind function has the priority)

6.4.8.3 Timer setting is available

6.4.8.4 Timer off and remote controller off signals have the priority compared with sleep function.

6.4.9 Auto-Restart function

The indoor unit is equipped with auto-restart function, which is carried out through an auto-restart module. In case of a sudden power failure, the module memorizes the setting conditions before the power failure. The unit will resume the previous operation setting (not including swing function) automatically after 3 minutes when power returns.

If the memorization condition is forced cooling mode, the unit will run in cooling mode for 30 minutes and turn to auto mode as 24°C setting temp.

If AC is off before power off and AC is required to start up now, the compressor will have 1 minute

delay when power on. Other conditions, the compressor will have 3 minutes delay when restarts.

6.4.10 8°C Heating(optional)

In heating operation, the preset temperature of the air conditioner can be as lower as 8°C, which keeps the room temperature steady at 8°C and prevents household things freezing when the house is unoccupied for a long time in severe cold weather.

6.4.11 Mode conflict

The indoor units can not work cooling mode and heating at same time.

Heating mode has a priority.

6.4.11.1 Definition:

	Cooling mode	Heating Mode	Fan	Off
Cooling mode	No	Yes	No	No
Heating Mode	Yes	No	Yes	No
Fan	No	Yes	No	No
Off	No	No	No	No

No: No mode conflict;

Yes: Mode conflict

6.4.11.2 Unit action

- Suppose Indoor unit A working in cooling mode or fan mode, and indoor unit B is set to heating mode, then A will change to off and B will work in heating mode.
- Suppose Indoor unit A working in heating mode, and indoor unit B is set to cooling mode or fan mode, then B will change to stand by and A will be no change.